

# Model PMD222

OWNER'S MANUAL

## PORTABLE CASSETTE RECORDER



**marantz®**

MARANTZ 700 NORTH COMMERCE STREET, AURORA, ILLINOIS 60504 USA

## FOREWARD

To obtain maximum performance and enjoyment from your Portable Cassette Recorder, please study these instructions carefully. Installing and operating your unit is not complicated, but the flexibility provided by its numerous operating features merit your becoming familiar with its controls and connections. Our recommended procedure will assure you of securing the superb performance for which your Cassette Recorder was designed.

For convenience, this manual is divided into two parts. The first part outlines a simplified operating procedure. The second part provides a more detailed description of the features of your Cassette Recorder, and explains some of the finer points of recording techniques.

For quick identification of the many controls, connections, and adjustments on your unit, all references to them in this manual are printed in **BOLDFACE** type.

## AFTER UNPACKING

It is advisable to retain all original packing material to prevent damage should you wish to transport your unit (refer to page 7 for Repacking and Shipping instructions). Be careful that you do not inadvertently throw away or lose the parts packed with the unit. Please inspect your Cassette Recorder carefully. Our very strict quality control and professional pride ensure that each unit leaves the factory in perfect condition. If the unit is damaged or fails to operate, immediately notify your dealer. If the unit was shipped to you directly, notify the transportation company without delay. Only you, the consignee, may institute a claim against the carrier for shipping damage. Save the carton and all packing material as evidence of damage for their inspection. Should assistance be required, the Marantz Company will cooperate fully in assisting your claim.

### PURCHASER'S RECORD

MODEL NO. \_\_\_\_\_  
(Located on Front of Unit)

SERIAL NO. \_\_\_\_\_  
(Located on Rear of Unit)

Cost \_\_\_\_\_ Date \_\_\_\_\_

This information becomes your permanent record of a valuable purchase. It should be filled in promptly then kept in a safe place along with your purchase receipt to be referred to as necessary for insurance purposes or when corresponding with Marantz.

### IMPORTANT

WHEN SEEKING WARRANTY SERVICE, IT IS THE RESPONSIBILITY OF THE CONSUMER TO ESTABLISH PROOF AND DATE OF PURCHASE. (YOUR PURCHASE RECEIPT OR INVOICE IS ADEQUATE FOR SUCH PROOF.)

## WARNING

**RECORDING OF TELEPHONE CONVERSATIONS OR COMMUNICATIONS WITHOUT THE CONSENT OF ALL PARTIES THERETO MAY BE A VIOLATION OF LAW.**

## QUICK REFERENCE INDEX

The drawings in Figure 1 provide a reference number for each of the panel features. These numbers reference a descriptive paragraph about the feature and may be located in the **PANEL FEATURES** section.

Before operating your new unit, take a few moments to acquaint yourself with some of the features and terminology you will encounter in this book.

## PANEL FEATURES

### ① ECM

Stands for a built-in electret condenser microphone. Use this microphone with the **INPUT SELECTOR** set to **MIC/TEL** and the **XLR-ECM** switch set to **ECM**.

### ② SPEAKER

### ③ CASSETTE COMPARTMENT

### ④ SHOULDER STRAP

### ⑤ STOP/EJECT BUTTON

The **STOP/EJECT** button serves a dual purpose. To stop the tape in any mode, depress the button lightly. To open the cassette compartment lid, release the button and depress again firmly.

### ⑥ RECORD BUTTON (REC)

Press this button together with the **PLAY** button to begin recording. If the cassette safety tabs have been removed, do not force the record button.

### ⑦ PLAY BUTTON

When depressed, the **PLAY** button engages the playback circuitry for flawless reproduction of previously recorded tapes.

### ⑧ REWIND/REVIEW BUTTON (REW/REVIEW)

Depress this button to rapidly rewind a tape. If depressed during playback, the tape will rewind until the button is released, at which point tape play resumes automatically.

### ⑨ FAST FORWARD/CUE BUTTON (FF/CUE)

Depress this button for rapid advancement to any desired point on the tape. If depressed during playback, the tape will advance until the button is released, at which point tape play resumes automatically.

### ⑩ PAUSE BUTTON

To stop a tape in play or record modes.

### ⑪ TAPE COUNTER

Used for easy reference and indexing. To return the numbers to "000" depress the **RESET** button.

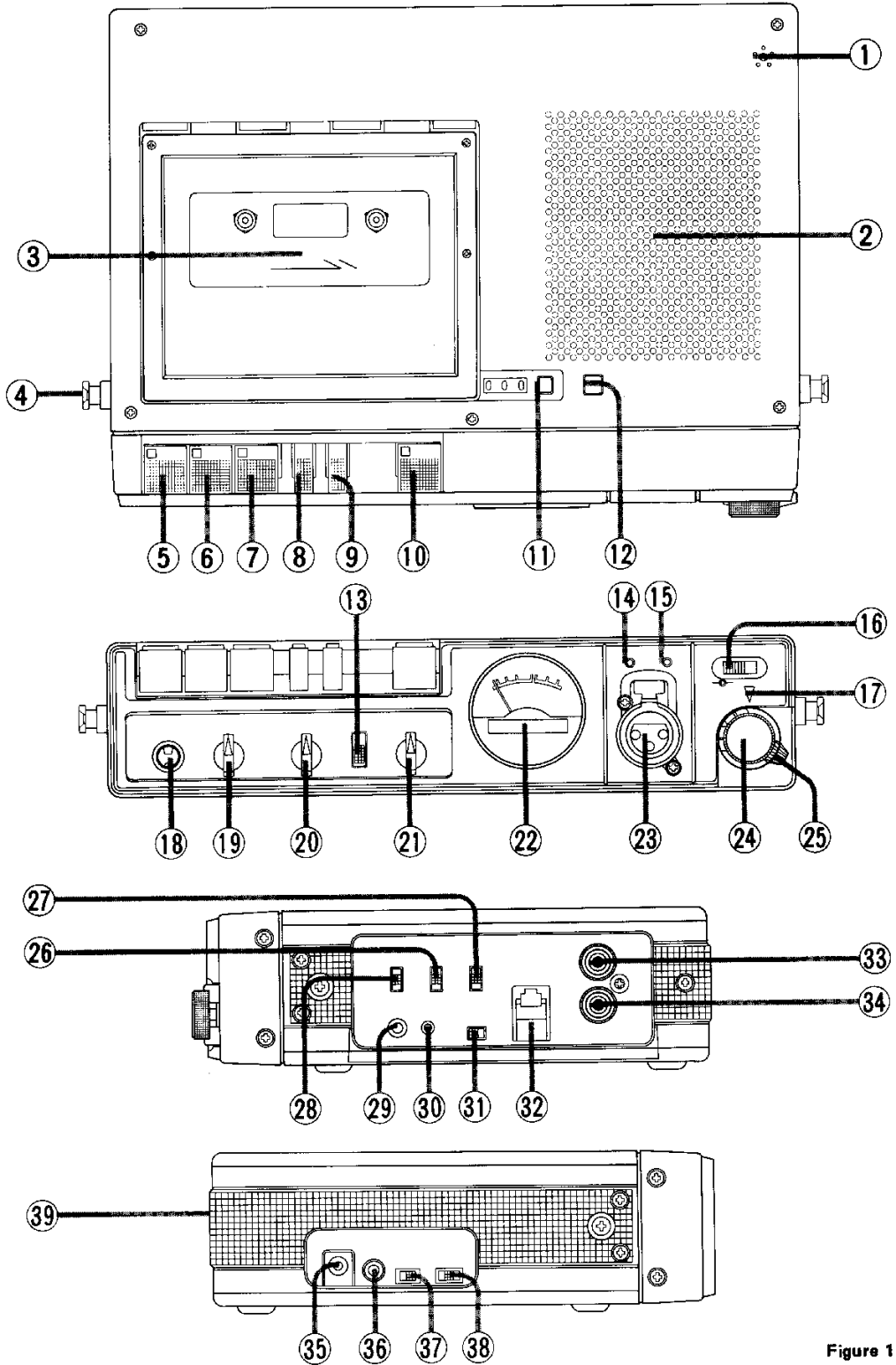

Figure 1

## WARNING

TO REDUCE THE RISK OF FIRE OR ELECTRIC SHOCK,  
DO NOT EXPOSE THIS APPLIANCE TO RAIN OR MOISTURE.

## 12 MEMORY REW SWITCH

When the tape is rewound with the **MEMORY REW** switch set to **ON**, tape travel stops when the counter reaches "999".

## 13 MONITOR SWITCH

When recording, this switch may be placed in the **SOURCE** position to monitor the signal before it is recorded, or the **TAPE** position to monitor the signal actually recorded on the tape.

### NOTE:

When the **MONITOR** switch is set to **SOURCE**, howling may occur. At that time, lower the monitoring volume.

## 14 PEAK LEVEL INDICATOR

During recording, the red LED indicates high level sounds which are too rapid to be measured by the **VU** Meter.

## 15 LOW BATTERY INDICATOR

When the batteries are exhausted, this indicator lights. When the battery condition is satisfactory, this indicator remains off.

## 16 TAPE SPEED SELECTOR

**STANDARD:** The tape travels at normal speed: 1-7/8 ips (4.75 cm/sec).

**LOW:** The tape travels at slower speed: 15/16 ips (2.38 cm/sec).

## 17 REC INDICATOR

When your unit is recording, this indicator will light up red.

## 18 PHONE JACK

Accepts headphones (optional) utilizing a standard stereo or mono phone plug.

## 19 LEVEL CONTROL

The **LEVEL** control regulates the sound volume heard through the speaker or headphone.

## 20 TONE CONTROL

Used to adjust the sound quality heard through the speaker, headphone or direct telephone system. When the knob is turned counterclockwise, the low frequency sound is decreased. When the knob is turned clockwise, the high frequency sound is increased.

## 21 PITCH CONTROL

When the **PITCH** control knob is at the "0" position, it is set at normal speed. Turn it in the **H** direction to increase the tape speed. Turn it in the **L** direction to decrease the tape speed.

## 22 VU METER

The **VU** meter indicates the average recording/playback level.

## 23 XLR TYPE MICROPHONE CONNECTOR

Connect an **XLR** type microphone connector. Use this microphone connector with the **INPUT SELECTOR** set to **MIC/TEL** and the **XLR-ECM** switch set to **XLR**. This input is balanced.

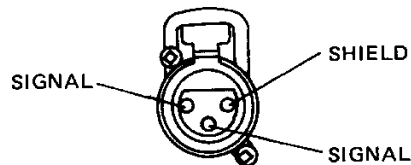

## 24 RECORD LEVEL CONTROLS

To increase the recording levels, turn the knob to the right.

## 25 REC MODE SWITCH

**MANUAL:** At this setting, the recording level can be adjusted manually to your preference.

**LIMITER:** At this setting, the transient high level input signals are automatically decreased to a safe recording level.

**ALC:** At this setting, the recording level is automatically set to optimum level.

## 26 ANC SELECTOR

Used to select flat (**NORMAL**), low cut ( / ) or high and low cut ( \ ) modes for a microphone, telephone pick-up or direct telephone recording according to the signal condition.

## 27 INPUT SELECTOR

Used to select an input signal between **LINE**, **MIC/TEL** and **DIRECT TELEPHONE**.

## 28 MICROPHONE ATTENUATOR SWITCH

For extremely loud volume microphone recordings, depressing this switch prevents input overload and better record level adjustment.

This switch also functions for direct telephone or built-in microphone recording.

## 29 MICROPHONE JACKS

Will accept any low impedance microphone (optional) utilizing a 3.5 mm phone plug.

When a telephone pick up is connected to this jack, the telephone line recording is possible. When this jack is used, the **XLR** and **ECM** cannot be used.

### NOTE:

When microphones are selected for recording do not monitor through speaker as this will cause howling (acoustic feedback) which could damage your audio equipment. Use headphones for monitoring.

## 30 REMOTE JACK

This jack accesses a 2.5 mm plug. With a microphone equipped with a remote switch, playback or recording can be stopped temporarily.

### 31 XLR-ECM SWITCH

Selects the XLR input and ECM.

### 32 DIRECT TELEPHONE MODULAR JACK

With a telephone line connected to the direct telephone modular jack, it is possible to record messages and play pre-recorded messages back through the telephone line.

### 33 LINE INPUT

Should be connected to the tape output jacks of your amplifier.

### 34 LINE OUTPUT

Should be connected to the tape monitor inputs of your amplifier.

### 35 EXTERNAL DC POWER INPUT JACK (DC 4.5 V)

This jack is provided to operate your portable cassette recorder from an external 4.5 volt DC power source.

### 36 EXT SP JACK

Accesses the 3.5 mm plug of an external speaker.

### 37 SPEAKER ON/OFF SWITCH (SPKR MON)

Place this switch in the ON position to monitor recordings through the built-in speaker.

### 38 TAPE SELECTOR

Selects the proper bias and equalization to suit the most common types of cassette tapes.

**NORM** — for normal ferric oxide tapes

**CrO<sub>2</sub>** — for chromium dioxide and other tapes requiring 70  $\mu$ s equalization and high bias

**METAL** — for metal tapes

### 39 BATTERY COMPARTMENT

Accepts three "D" size batteries or the Marantz Rechargeable Battery Pack (RB430).

## POWER SOURCES

Your Cassette Recorder may be operated using any of three power sources:

#### BATTERY OPERATION (BATTERIES NOT INCLUDED)

- Open the Battery Compartment cover by depressing the finger grip and pulling out (See Figure 2 on Page 16).
- Install three "D" size batteries.

#### IMPORTANT:

Each battery should be installed observing the correct polarity as shown in Figure 2 on page 16.

- Close the battery compartment cover.

#### NOTE:

When the LOW battery indicator lights with the power supplied, replace all the batteries.

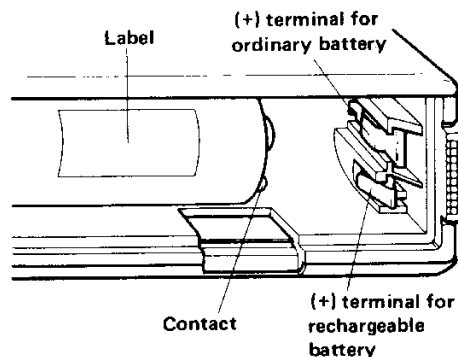

Figure 3

## RECHARGEABLE BATTERY PACK

The RB430 can be recharged again and again, thereby eliminating the need for frequent battery replacement.

### RECHARGEABLE BATTERY PACK INSTALLATION

Open the battery compartment cover, then install the battery pack by pressing the flat negative (–) side of the pack against the spring and positioning the positive (+) side of the pack against the charging terminal of the recorder. Make sure that the label side of the battery pack is facing up.

### CHARGING THE BATTERY PACK

The battery pack can be charged by connecting the AC adaptor. (There is no need to operate the recorder at this time.)

### AC POWER

The AC adaptor accessory makes it possible to operate the recorder on AC power. Before plugging the adaptor into an AC outlet, check the outlet voltage and set the AC adaptor for that voltage. After wards, insert the AC adaptor's output plug into the 4.5 V DC jack in the recorder.

#### NOTE:

The RB430 Battery Pack is automatically recharged, and the batteries disconnected, when the power cord is connected to the AC receptacle.

#### CAUTION:

When not using the recorder, unplug the AC adaptor from the wall outlet and the DC jack on the recorder.

### CAUTION FOR RECHARGEABLE BATTERY

It takes approximately 16 to 24 hours to recharge the RB430 Battery Pack. Charging for a longer period of time will overcharge the RB430, and will shorten the life of your battery pack.

The battery can be destroyed if shorting, so be careful to avoid shortage.

### OPERATION DURING CHARGING

It is advisable not to operate the unit during charging as it could cause problems with the AC adaptor.

## TAPE MONITORING

In addition to source monitoring, the PMD222 contains a third head which enables you to monitor directly from the tape as a recording is made. To use this feature, place the **MONITOR** switch in the **TAPE** position and turn up the **LEVEL** control.

Source and tape monitoring may be accomplished through the use of the internal speaker, external speakers, line output connections or a headphone.

### NOTE:

A stereo headphone can also be used.

### CAUTION:

To avoid audio feedback when making a microphone recording, place the microphone a suitable distance away from the speaker. If desired, the internal speaker may be disconnected by placing the **SPKR MON** switch to the **OFF** position.

## ADVANCED RECORDING TECHNIQUES

### CONTROLLING THE RECORDING LEVEL

The best method of controlling the recording level is determined by the content of the particular program source. Use the guidelines below to obtain the desired recording results.

#### REC MODE

**LIMITER:** Allows you to manually set the recording level of the **REC LEVEL** control while an internal limiter circuit automatically prevents overload distortion resulting from sudden level peaks.

**MANUAL:** Permits manual control of the recording level for maximum dynamic range.

**ALC:** At this setting, the recording level is automatically set to the optimum level regardless of the **REC LEVEL** control setting.

## SETTING THE RECORD LEVEL

### PROCEDURES FOR RECORDING WITH THE LIMITER

Turn on the **LIMITER** after setting the recording level. To set the level, switch to **MANUAL**, then adjust the **REC LEVEL** control while watching the **VU** meter.

Ordinarily, **VU** meter needle deflection should be as large as possible, which the peak level meter should only light occasionally. If the indicator lights continuously, the level is too high; this will result in distorted sound. Conversely, if the **VU** meter needle stays on the left side of the scale and the indicator does not light at all, the level is too low and the poor **S/N** ratio will result.

### HIGH VOLUME MICROPHONE RECORDINGS

Certain microphone recording situations may result in extremely high microphone input levels. In such cases the **REC LEVEL** control cannot be set to the desired position without **VU** meter deflection far into the red zone. A greater range of **REC LEVEL** control rotation can be obtained by the **MIC ATT** switch. This switch will attenuate the input level by 10 dB or 20 dB. In normal recording, leave the **MIC ATT** switch in the "0 dB" position.

## LONG PLAY

When the **SPEED** selector is set to **LOW**, the tape speed is halved and the recording time doubles.

### NOTE:

Do not change the **SPEED** selector setting during recording.

## TO PROTECT VALUABLE RECORDINGS

You can prevent your valuable recordings from being erased by removing the safety tabs on your cassette tape.

Use a small screwdriver to breakout one or both safety tabs. (Figure 4 on Page 16 shows how to remove the side "A" safety tab.)

The recording capability of either side of a cassette can be restored by covering the appropriate opening where the tab was removed with cellophane tape. (Figure 5 on Page 16 shows cellophane tape applied to side "A" safety tab opening.)

### TO PLAYBACK

1. Insert a pre-recorded cassette, or playback a tape just recorded — rewind the tape to the beginning.
2. Be sure the EQ setting of the **TAPE SELECTOR** switch matches the type of tape you are using.
  - METAL 70  $\mu$ s
  - CrO<sub>2</sub> 70  $\mu$ s
  - NORMAL 120  $\mu$ s
3. Place the **MONITOR** switch in the **TAPE** position.
4. Depress the **PLAY** button.
5. Adjust the **LEVEL** control for a comfortable listening level.

### NOTE:

For playback through an optional headphone, or line output connections, refer to the **SPECIAL FEATURES SECTION**.

### REWIND

Check that the **MEMORY REW** switch is in the **OFF** position. To rewind a tape, depress the **REW/REVIEW** button. The tape will rewind to the beginning. To stop at other desired points, depress the **STOP/EJECT** button.

### REVIEW

Check that the **MEMORY REWIND** switch is in **OFF** position. Partially depressing the **REW/REVIEW** button during playback operation permits you to monitor information on the tape as it rewinds. When fully depressed, no sound will be heard. When the desired portion of the tape is reached, release the button to automatically resume tape play.

### FAST FORWARD

To rapidly advance the tape in a forward direction, depress the **FF/CUE** button. When the desired point is reached, depress the **STOP/EJECT** button.

### CUE

Check that the **MEMORY REW** switch is in the **OFF** position. Partially depressing the **FF/CUE** button during playback operation permits you to monitor information on the tape as it is rapidly advanced. When fully depressed, no sound will be heard. When the desired portion of the tape is reached, release the button to automatically resume tape play.

## PAUSE

Depress the **PAUSE** button to momentarily stop the tape in the record or playback modes. Depress the button a second time to resume tape motion.

The pause feature provides for the convenient editing of material while recording or playing back individual short segments of tape.

### CAUTION:

The **FF** and **REW** buttons will not lock if no battery or AC power is supplied. This is not an indication of trouble with the unit.

With the **MEMORY REW** switch set to **ON**, the **REW** and **FF** button cannot be locked when the tape counter reads 900 – 999

## PITCH CONTROL

The **PITCH** control operates only during playback. Normal speed is indicated when the **PITCH** control is set to the center (click) position.

### CAUTION:

- When recording using a microphone, howling may result with the **SPKR MON** switch set to **ON**. At that time, use headphones or set the **SPKR MON** switch to **OFF**.
- At the beginning or end of a recording, popping noises are sometimes recorded on the tape. To prevent this, proceed as follows.
  1. Press the **PAUSE** button.
  2. Press the **RECORD** and **PLAY** button.
  3. Press the **PAUSE** button again to start recording.
  4. Press the **PAUSE** button to stop the tape.
  5. Press the **STOP** button to stop recording.
- When recording with batteries, using the speaker or headphones to monitor may exhaust the batteries. Set the monitor control to zero except when necessary.
- When the batteries are exhausted, the tape moves, but recording is not possible. Refer to the battery indicator to see if your batteries need to be replaced.
- When the unit is used at low temperatures, the power consumption of the unit increases and the battery voltage decreases. In low temperatures, the battery life may be shortened.

## SPECIAL FEATURES

### USE OF A HEADPHONE

For private listening, connect a low impedance headphone (optional) incorporating a 6 mm phone plug to the **PHONE** jack.

### LINE IN-OUT CONNECTIONS

An external component may be connected to these jacks to monitor or record from your cassette recorder.

### SHOULDER STRAP

The adjustable shoulder strap provides a convenient method for carrying your cassette recorder during mobile operation.

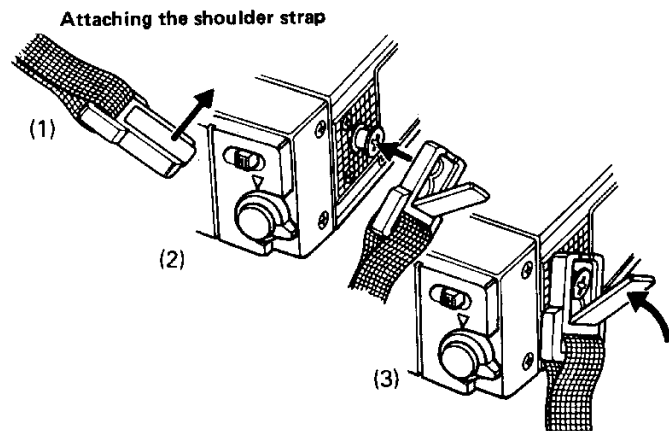

## TOTAL SHUT OFF

This built-in feature automatically disengages the transport and shuts off the unit when the end of the tape is reached in any mode of operation.

## AUTO REPLAY

When the **REW** button is pressed and locked while the unit is in the play mode, and the **MEMORY REW** switch is set to **ON**, the tape will rewind until the counter reaches "999". Tape travel then automatically starts in the play mode. Playback can be started at any point desired by zeroing the counter at that point in advance.

## MEMORY REW

When the **REW** button is pressed with the **MEMORY REW** switch set to **ON**, tape travel stops when the counter reaches "999".

Playback can be started at any point desired by zeroing the counter at that point in advance.

## USING THE DIRECT TELEPHONE SYSTEM

Connect the unit to the telephone line. Use a standard telephone cord with modular plugs on both ends (not provided with unit).

It may be necessary to use a modular "Y" connector to connect the telephone and the unit simultaneously. (This accessory is not provided with the unit).

When recording while the handset is off the hook, switch the internal speaker off (**SPEAKER MONITOR SWITCH**).

It is also possible to record or playback a signal while the handset is on the hook. This feature is useful while recording or transmitting FSK computer data or when an audio signal (e.g., pre-recorded tape) is transmitted over the telephone line. Recording while the telephone is on the hook will prevent any acoustic interference during recording. When the unit is not in use, disconnect it from the telephone line.

## TO ERASE A TAPE

1. Insert the cassette with the side you wish to erase facing up.
2. Set the **REC LEVEL** to minimum (fully counterclockwise).
3. Simultaneously press the **REC** and **PLAY** buttons.

## PROPER CARE AND MAINTENANCE

- Periodically clean the tape heads, guides and pinch roller with a soft cloth or cotton swab moistened with denatured alcohol or a commercial head cleaning solution. Clean the heads after removing the batteries and disconnecting the AC adaptor. Head cleaning procedures are as described below.
  1. Depress the **STOP/EJECT** button to open the cassette compartment.
  2. Depress the **PLAY** button to engage the head assembly. After cleaning has been completed, depress the **STOP/EJECT** button to disengage the head assembly.
- Tape head and guides also become magnetized over a period of time, and should be demagnetized periodically using a commercial head demagnetizer.
- When cleaning the cabinet, use a soft cloth slightly dampened with a mild solution of detergent and water. NEVER use scouring pads, scouring powders, harsh chemicals or petroleum products.
- Weak batteries can leak and cause corrosion. If the recorder will not be used for a long period of time or if it is used extensively on AC adaptor, remove the batteries.
- Extended use of this unit in areas of extreme heat or humidity should be avoided.

## REPAIRS

Only the most competent and qualified technicians should be allowed to service your cassette recorder. The Marantz company and its factory trained technicians have the knowledge and special equipment needed for repair and calibration of this precision instrument.

In the event of difficulty, please call the proper toll free number listed below, and ask for Marantz Service:

For the Continental United States (except ILL):

800-447-1970

For Illinois: 800-322-0800

For Hawaii and Alaska: 800-447-0890

When delivering the product for service, you should take a copy of your purchase receipt and a full description of the problems you have encountered.

## REPACKING FOR SHIPMENT

Should it become necessary to repack your unit for shipment to the factory, to an authorized service station, or elsewhere, please observe the following precautions:

- a. Pack the unit carefully, using the original material as shown in Figure 7 on Page 16.
- b. Ship via a reputable carrier and obtain a shipping receipt from the carrier.
- c. Insure the unit for its full value.
- d. Be sure to include your return address on the shipping label.